

3/4" SCH 40 (STD PIPE)  
BALUSTERS INSERTED  
IN HOLE AND TACK  
WELDED OPPOSITE  
TRAFFIC

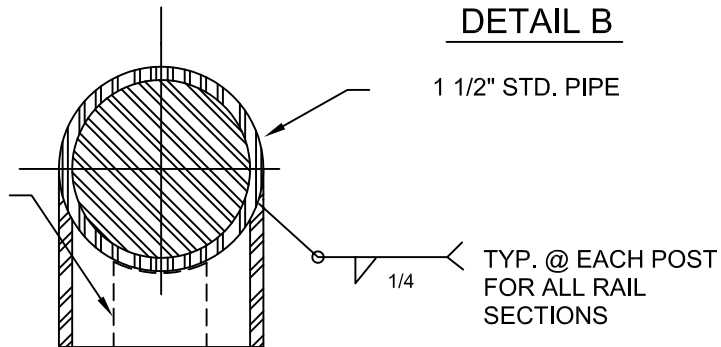

**NOTES:**

1. MATERIAL FOR PEDESTRIAN HANDRAIL SHALL BE ALUMINUM (ASTM B-429) OR GALVANIZED STEEL (ASTM 120) AS APPROVED BY THE CITY ENGINEER.
2. SEE STANDARD DRAWING No. 3-27 FOR ADDITIONAL FABRICATION AND SPECIFICATION REQUIREMENTS.
3. PROVIDE SLIP JOINTS AT STAIRWAY EXPANSION JOINTS AND AT EVERY 24 FEET ON CENTER MAXIMUM.

**PEDESTRIAN HANDRAIL**